

**NAD**

**6125**

**STEREO  
CASSETTE DECK**

**INSTRUCTIONS  
FOR INSTALLATION  
AND OPERATION**

1. Line IN
2. Line OUT
3. AC Power Cord

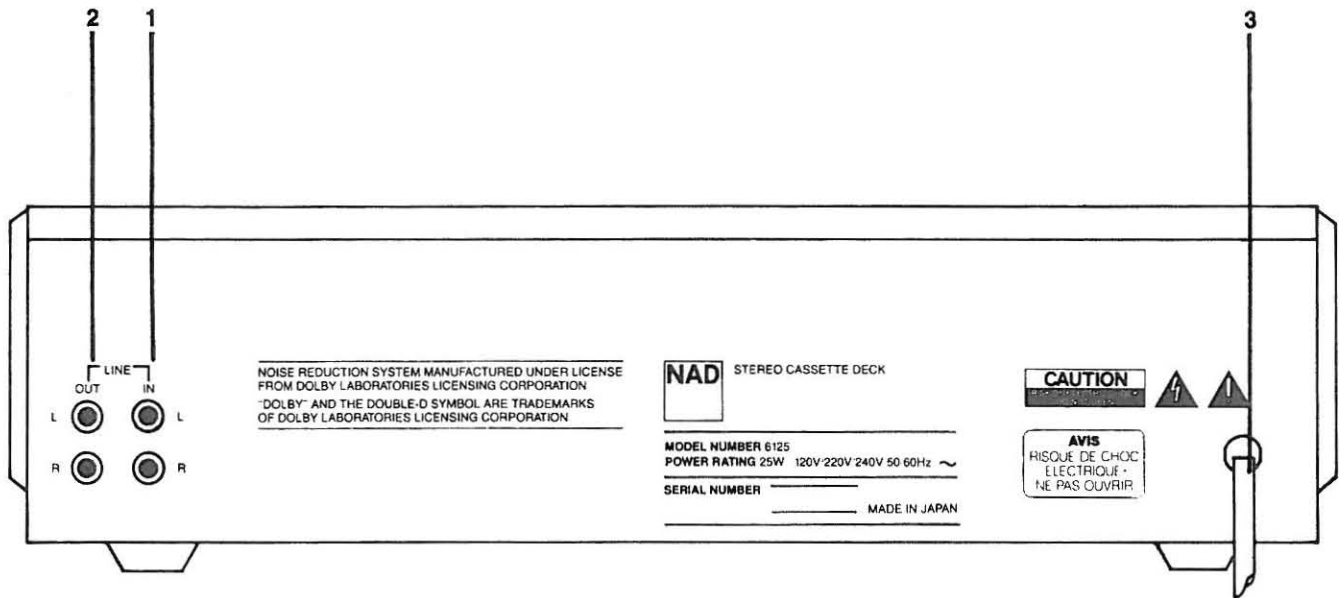

**CAUTION**

CAUTION: TO REDUCE THE RISK OF ELECTRIC SHOCK, DO NOT REMOVE COVER (OR BACK). NO USER-SERVICEABLE PARTS INSIDE. REFER SERVICING TO QUALIFIED SERVICE PERSONNEL.

1. Power
2. Eject
3. Turns Counter
4. Fast Forward
5. Rewind
6. Play
7. Stop
8. Record
9. Pause
10. MPX Filter
11. Dolby NR\*
12. Tape Selector
13. Record Level
14. Recording Level Display
15. MIC

\*Dolby Noise Reduction system manufactured under license from Dolby Laboratories Licensing Corporation. "Dolby" and the double-D symbol are trademarks of Dolby Laboratories.

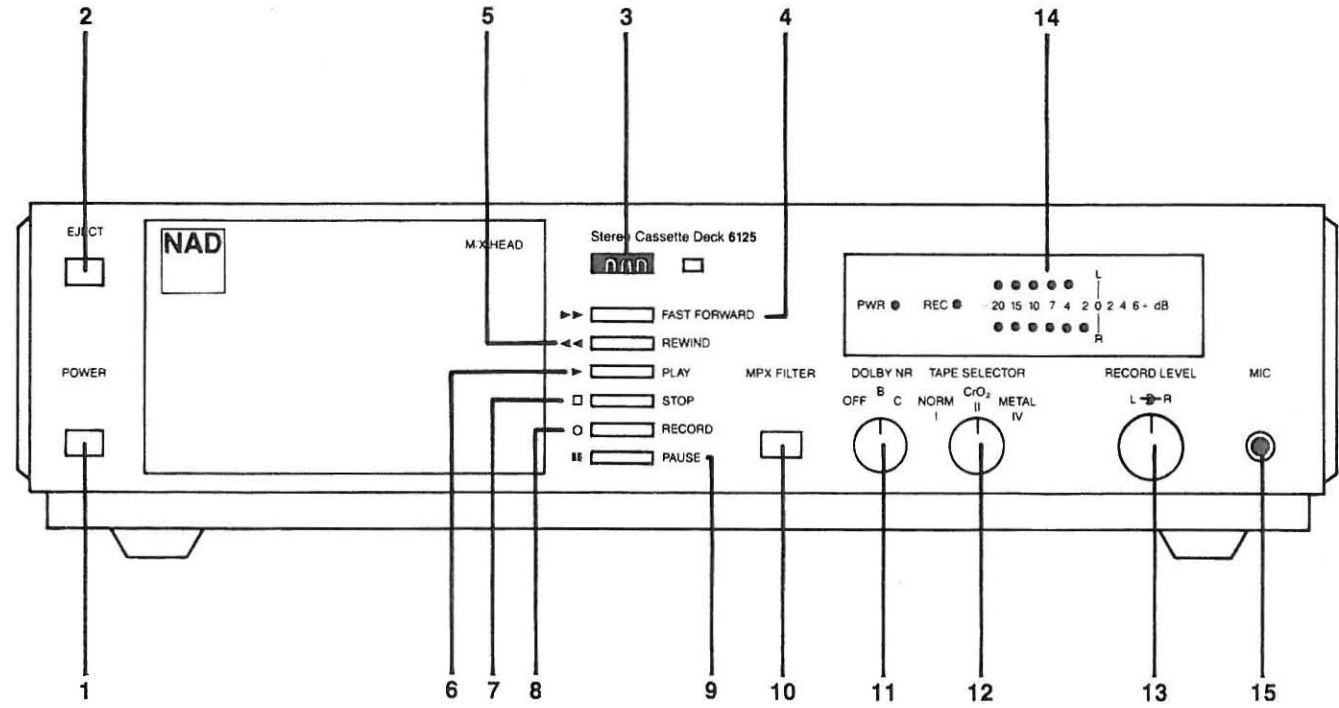

## REAR PANEL CONNECTIONS

**1. LINE IN.** The NAD 6125 is intended to be connected to the Tape REC and PLAY (output and input) jacks at the rear of any conventional stereo amplifier. Insert the phono plugs at one end of a stereo connecting cable fully into the LINE IN sockets on the 6125. At the other end of the cable, insert the plugs into the TAPE OUT or RECOrd jacks of the amplifier.

Use the color coding of the plugs to identify the channels; for instance, if one of the plugs at each end of the cable is red, connect the red plug to the R (right channel) socket of both the amplifier and the NAD 6125.

**2. LINE OUT.** To play tapes, plug one end of a stereo connecting cable into the NAD 6125's LINE OUT jacks, and plug the other end into the TAPE IN, PLAY, or MONitor input jacks of the amplifier. Make sure that each plug is inserted fully into its socket, and observe the color coding of the plugs to ensure that the stereo channels are connected consistently.

**3. AC POWER CORD.** Connect the AC power cord to a convenient wall outlet or to an "unswitched" AC convenience outlet at the rear of your amplifier.

**A note on installation.** The excellent performance of the NAD 6125 stereo tape recorder depends on an array of precisely machined parts, fine bearings, smoothly polished surfaces, sensitive detection of the weak magnetic fields in tape recordings, and amplification of very small signal voltages. Consequently the recorder's performance can be adversely affected by external magnetic fields, electrical interference, vibration, heat, moisture, or chemical fumes.

Thus if it is placed directly on top of a power amplifier, the 6125 may pick up a low-frequency hum from the amplifier's power transformer. If you wish to install it next to an amplifier on the same shelf, place the 6125 on the left so that its cassette compartment will be located away from the amplifier.

The 6125 should not be placed on a loudspeaker or on a television set (a source of strong magnetic fields as well as vibration), nor in direct sunlight, nor very close to a steam radiator, nor in a workshop where metal filings and chemicals are found. The 6125 will function best at temperatures that are comfortable for people, and it can be stacked or shelved with the remaining components in your stereo system.

If you are located near a powerful television or radio transmitter (including a citizen's band or short-wave unit) you may pick up interference, especially when playing previously recorded tapes. If you encounter this type of radio-frequency interference, you may succeed in reducing it by experimenting with the location and orientation of the recorder. If the problem persists, your dealer or a service shop may be able to add approved circuit modifications or extra internal shielding.

**Connecting two recorders.** Some stereo amplifiers have two sets of tape input/output jacks, with front-panel switching

to permit using either of two tape decks for recording or playback and to permit copying tapes from one to the other. If your amplifier has only one set of connections for a tape recorder, it is still possible to use two recorders with it. The most convenient and flexible method is to purchase an external switch-box (Tandy Radio Shack #42-2105 or equivalent), which will provide input/output connections for up to three recorders and allow copying among them. The alternative methods described below are less flexible, but they cost less and yield equally good recordings.

**Copying.** Connect the "copying" recorder (the machine on which the new copy will be recorded) to the amplifier's TAPE recording/playback jacks as described above. Then connect to the amplifier's AUXiliary input a cable from the Line Output jacks of the "source" recorder (the machine containing the tape that you want to copy), and switch the amplifier's Input Selector to AUX.

If an AUX input is not available, an alternative procedure is to disconnect the cable from the amplifier's tape RECOding output, and connect the "source" recorder's Line Output directly to the copying recorder's Line Input. With this connection you must activate the copying recorder's RECORD function in order to monitor the playback output of the source machine.

**Parallel recording.** Two recorders can be wired in parallel to permit simultaneous recording on both. Obtain two "Y-connector" adapters, each having two female phono sockets and one male phono plug (e.g., Tandy Radio Shack #42-2436 or equivalent). Plug one Y-connector into the Right channel Tape RECOding jack of the amplifier, and connect the Right channel (red) plugs of two stereo cables to the Y-connector's two sockets. Plug the other Y-connector into the Left channel Tape REC jack, and connect the left-channel plugs (usually black) of the two stereo cables to the Y-connector's sockets. Finally, at the opposite end of the two stereo cables, connect to the Line Input jacks of the two recorders.

This hookup allows you to record freely on either machine, or simultaneously on both, but not to copy tapes from one to the other.

**NOTE:** This method of parallel connection works well for recording, but *not* for playback. If you use Y-connectors to combine the Line Output signals from two tape decks, each machine's output will tend to short-circuit the other's, yielding a low playback level and possibly higher distortion. Only one tape deck's Line Output signals can be fed to the amplifier's Tape PLAY input jacks.

To hear the playback from the second recorder, connect its Line Output to the amplifier's AUX input. But observe this precaution: never switch the amplifier's Input Selector to AUX while recording on the machine whose output is connected to AUX; doing so would create a feedback oscillation that could damage your loudspeakers.

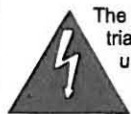

The lightning flash with arrowhead, within an equilateral triangle, is intended to alert the user of the presence of uninsulated "dangerous voltage" within the product's enclosure; that may be of sufficient magnitude to constitute a risk of electric shock to persons.



The exclamation point within an equilateral triangle is intended to alert the user of the presence of important operating and maintenance (servicing) instructions in the literature accompanying the appliance.

## FRONT PANEL CONTROLS

**1. POWER.** Press this switch to turn on the power to the cassette deck. Press again and release to turn the power off.

A green LED at the left end of the recording level display is illuminated when the power is on.

The capstan drive motor runs continuously when the power is on. To prolong the life of the motor, switch the power on only when the recorder is being used, and switch it off when you are listening to broadcasts or disc records.

**2. EJECT.** When this button is pressed, the door of the cassette compartment swings open to allow a tape to be inserted or removed. The tape cassette is held in a carrier within the door assembly.

To insert a tape cassette, remove it from its protective box. Hold it so that its thick edge faces down, and so that the full tape spool is at the left side of the cassette. Press the EJECT button to open the door, slide the cassette into the door's carrier slot, and push the door to close it.

**NOTE:** Always press STOP to disengage the tape transport mechanism before pressing EJECT to open the door. (If the machine is in the PLAY or RECORD mode the EJECT button is automatically disabled for safety.)

**3. TURNS COUNTER.** This counter registers the turns of the take-up spool in the cassette. Press the adjacent button to re-set the counter to 000 at the beginning of a tape; then the counter readings will provide a convenient method of identifying the locations of selections on the tape. It will accumulate a maximum count of approximately 450 over the length of a C-60 tape, about 700 for a C-90, and about 900 for a C-120.

**4. FAST FORWARD/CUE.** This button winds the tape rapidly forward from the left to the right, i.e., from the beginning toward the end of a recording.

If the tape transport is in the STOP mode, disengaged from the tape, then the button will latch down when pressed; the tape will continue to fast-wind forward until you press STOP or until the end of the tape is reached. At the end of the tape the transport automatically disengages, returning to the STOP mode after a brief delay. Since the record/playback head is not in contact with the tape, no sound is heard.

If the tape transport is in the PLAY (or PAUSE) mode, pressing the FAST FORWARD button activates the CUE function. The tape winds forward *only as long as you continue to press the FAST FORWARD button in*. The transport remains engaged, automatically resuming PLAY (or PAUSE) when you release the button. The heads remain in contact with the tape, so any recorded material on the tape will be heard as a loud, high-pitched squeal; this allows you easily to find where recorded selections begin and end. TURN DOWN YOUR AMPLIFIER VOLUME CONTROL to prevent damage to your speakers when using this cue mode.

**5. REWIND/REVIEW.** This button winds the tape rapidly from the right (the take-up spool) toward the left (onto the supply spool).

If the tape transport is in the STOP mode, disengaged from the tape, then the REWIND button will latch down when pressed; the tape will continue to rewind rapidly until you press STOP or until the beginning of the tape is reached. Since the head is not in contact with the tape, no sound will be heard.

If the tape transport is in the PLAY (or PAUSE) mode, pressing the REWIND button activates the REVIEW function. The tape winds rapidly back *only as long as you continue to press the REWIND button in*. The transport remains engaged, automatically resuming PLAY (or PAUSE) when you release the button. The heads remain in contact with the tape while it winds, so any recorded material on the tape will be heard as a loud, high-pitched squeal; this allows you easily to find where

recorded selections begin and end. TURN DOWN YOUR AMPLIFIER VOLUME CONTROL to prevent damage to your speakers when using this cue mode.

**6. PLAY.** When this button is pressed, the tape is moved from left to right at normal playing speed, the recorder's heads are brought into contact with the tape, and the playback circuits are activated. At the end of the tape, the transport automatically stops and disengages itself from the tape.

**7. STOP.** This button stops the tape motion and disengages all of the tape transport functions (except PAUSE). If the machine was in PLAY or RECORD, pressing STOP causes the heads to retract from the tape, allowing the door to be opened by the EJECT button.

**8. RECORD.** Pressing this button activates the recording circuits and also engages the transport to move the tape over the heads so that a recording can be made. The red REC light in the recording level display illuminates to indicate that the NAD 6125 is in the recording mode. When recording, the machine automatically erases any previous recording that may be on the tape.

**NOTE:** In many tape recorders the REC button only switches on the recording circuits, and it is necessary to press both REC and PLAY to engage the tape and make a recording. But in the 6125 the single REC button commands the entire recording process. One-button recording is convenient, but it means that if you accidentally press REC instead of PLAY when you want to play back a tape, the machine will immediately go into the recording mode and begin to erase the recording that you wanted to hear. To prevent such accidents, remove the erasure-prevention tabs (as described later) from any recorded cassettes that you don't intend to re-record on. With these tabs removed, the REC button cannot be depressed.

To stop recording and de-activate the recording circuits, press STOP.

To stop recording briefly while leaving the recording circuits activated, press PAUSE; then press and release PAUSE again when you are ready to resume recording.

**9. PAUSE.** Pressing this button once retracts the rubber pinch roller from the capstan, thus halting the motion of the tape in the PLAY and RECORD modes, while leaving the playback or recording circuits active.

Pressing and releasing the PAUSE button a second time provides an instant resumption of tape motion for playback or recording.

**NOTE:** The PAUSE control is intended to stop the tape motion *temporarily*. To stop the tape for more than a few minutes, use the STOP button.

The PAUSE function can only be disengaged by pressing and releasing the PAUSE button; unlike the other functions of the tape transport, PAUSE does not automatically disengage when STOP is pressed. If you forget that you have left the PAUSE mode engaged, the Model 6125 may appear to be malfunctioning when you try to record or play tapes. When you press RECORD, for example, the red RECORD light will illuminate and the incoming signal will register on the recording level display, but no signal will be recorded on the tape until the PAUSE is released. (Then the changing number in the TURNS COUNTER will provide confirmation that the tape is moving.)

**10. MPX FILTER.** This filter is intended for use when you are making recordings with Dolby B noise reduction. Any ultrasonic interference in the input signal during recording, such as a multiplex pilot signal in an FM tuner, may cause mistracking of the Dolby circuit and yield dull sound when the recording is played back. To prevent this mistracking and preserve a flat frequency response with Dolby NR, the MPX filter should be switched ON (by pressing the button in) when-

ever a recording is made using Dolby B. The filter blocks frequencies higher than about 15 kHz in the signal.

When playing previously recorded tapes, a very slight extension of high-frequency bandwidth may be obtained by switching the MPX filter OFF (button out). But remember to switch back in when making recordings with Dolby B.

If you make any recordings with the Dolby NR switched OFF, the MPX filter is optional. It is also optional when you are using Dolby C NR, since the Dolby C circuit contains some ultrasonic filtering of its own.

**11. DOLBY NR.** The recorder is equipped with two types of Dolby noise reduction. Dolby C provides the greatest quieting of tape hiss, important when taping "live" musical performances or wide-range recordings (digital records, for example). Dolby B provides optimum compatibility with older tape recorders, portable and automobile stereo tape players, and should also be used when playing most pre-recorded music cassettes.

Each type of NR involves complementary processes that are intended to match each other in *both* recording and playback. Thus if a tape is recorded with Dolby C noise reduction, it must also be played back with the Dolby C circuit operating in order for the benefits of the Dolby system to be obtained. Similarly, if Dolby B is used in recording it should be used in playback as well. To avoid confusion, it is recommended that you label each cassette "B" or "C" when it is recorded, to indicate the type of noise reduction used.

Both types of Dolby NR operate by selectively compressing the dynamic range of the middle and high frequencies in the signal during recording. I.e. the circuit selectively boosts the level of those middle-to-high frequency sounds that occur at a naturally low level, so that these sounds are recorded on the tape at a level substantially higher than the tape's own hiss. Then, in playback, these signals are expanded back to their original dynamic range; the quiet middle and high frequency sounds that were boosted are finally cut back down to their original levels, and the tape's hiss is reduced at the same time.

Dolby B and C differ in the amount of complementary boost/cut that they provide, and in its frequency distribution. Dolby B operates mainly at high frequencies and suppresses tape hiss by a maximum of 10 dB. Dolby C operates at both middle and high frequencies and reduces hiss by as much as 20 dB. The two Dolby systems are *not* interchangeable. If you record with Dolby B and play back with Dolby C (or vice versa) the tonal balance of the musical sound will be substantially altered.

Also, any brightening or dulling of the sound that is caused by a mismatch between the recorder and the tape will produce mistracking in the Dolby circuit and yield an exaggerated brightening or dulling of the playback sound. So when the Dolby circuits are to be used, it is especially important that the TAPE SELECTOR be correctly set to match the tape (both in recording and in playback).

**12. TAPE SELECTOR.** This switch selects the correct bias (for recording) and equalization (for playback), for each of three standard types of cassette tape. Whenever you record or play a tape, this switch must be set to match the tape. If you are not careful about this, the clarity and tonal balance of your recordings will vary a great deal, especially when Dolby noise reduction is used.

**I. Normal.** The largest variety of cassette tapes are intended for use with the NORMAL setting of the TAPE SELECTOR. Look at the cassette package for a statement of "normal bias" or "120  $\mu$ sec" equalization. In general, tapes described as "ferric oxide," "low noise," or having the Roman numeral I in their designation, are intended for the NORMAL setting.

**II. CrO<sub>2</sub>.** The CrO<sub>2</sub> setting is intended for tapes employing chromium dioxide or the "chrome-equivalent" cobalt-doped high-bias ferric oxide. Usually these are identified as requiring "high bias," "70  $\mu$ sec" equalization, or have the Roman numeral II in their designation.

**IV. Metal.** The Metal setting should be used with metal-particle tapes, which may be labeled with the Roman numeral IV.

While the TAPE SELECTOR switch provides the large changes in recording bias and playback equalization that are needed to accommodate the three standard classes of tape, there are significant brand-to-brand differences in sensitivity and frequency response among tapes *within* each group. If you wish, you can use the 6125 to make recordings on any brand and type of tape, using any setting of the TAPE SELECTOR, without harming either the recorder or the tapes. And by experimenting with various tapes you may exploit their different tonal qualities to produce pleasing results—using the recorder, in effect, as a tone control.

But the basic purpose of a high-fidelity tape recorder is to provide an exact replica of the original sound, capturing and preserving it for later playback. This is what the NAD 6125 is designed to do. If you want to make the most accurate recordings, you must use tapes similar to those used in the factory for calibrating the recorder's circuits. This is especially important when Dolby noise reduction is used, because any departure from accurate high-frequency response in a recording (due to a mismatch between recorder and tape) will cause decoding errors in the Dolby circuit during playback—and this, in turn, will cause larger errors in frequency response, making the sound excessively bright or dull.

For information on tapes that are compatible with the NAD 6125, see your NAD dealer.

**13. RECORDING LEVEL.** This knob controls the strength of the audio signal fed to the tape when a recording is being made. The signal strength is shown on the recording level display, above.

The RECORD LEVEL control is actually two co-axial controls (one for each stereo channel), friction-coupled so that they normally rotate together. It is possible to alter the stereo balance by adjusting the two controls differently. The left channel is controlled by the central part of the knob, while the right channel is controlled by the outer part (the sleeve around the circumference of the knob).

**14. RECORDING LEVEL DISPLAY.** This dual row of LEDs displays the peak level of the signal in each channel during recording or playback. The LEDs ranging from -20 dB to 0 dB are green and indicate normal recording levels. The +2, +4, and +6 dB LEDs are red and indicate the maximum permissible levels.

In general, you should adjust the recording level so that the loudest portions of the music are recorded at levels between -4 and +2 on the display. With music that spans a large range of volume levels, such as a symphony, this may mean that the quiet portions of the music will be recorded at indicated levels of -20 dB or even lower (with no LEDs illuminated); this is normal.

To learn how to set optimum recording levels, the following experiment is recommended. Select a typical recording of music and record an excerpt from it several times in succession, setting the recording level progressively higher each time. For example set the maximum peak level at about -10 dB the first time, and repeat it at about -4, at 0, at +4, and finally at over +6 dB. Then play back the recordings and listen for symptoms of tape saturation in the sound. (Adjust your amplifier's volume control to compensate for the different loudness levels of the sample recordings, so that you can focus your attention on the quality of the sound without being

distracted by volume differences.)

At a peak level of  $-10$  dB the sound should be clear, open, and detailed, but the background of tape hiss may be bothersome. At peak levels of  $+4$  or  $+6$  dB you probably will begin to hear the effects of tape saturation: boomier bass, mushy midrange, or dull treble. Also, tape saturation will reduce the peak levels: a signal that was recorded at  $+4$  dB may play back at only  $0$  or  $+2$  dB.

The optimum recording level is the highest level that you can use (in order to minimize audible hiss in playback), but *without* encountering audible symptoms of tape saturation. As a general rule, you can use higher recording levels for brief transient sounds (such as drumbeats) than for continuous, sustained tones (e.g., the singing voice). And you can use higher recording levels for sounds whose energy is concentrated at midrange frequencies (e.g., spoken voice) than for sounds having a great deal of energy at very high frequencies (cymbals, bells, harpsichord) or at very low frequencies (pipe organ, bass drum). With the latter, the peak level usually should be set no higher than about  $-2$  dB.

When in doubt it usually is best to err on the conservative side, sacrificing a bit of potential signal-to-noise ratio in favor of a little extra undistorted headroom for musical peaks. With Dolby C noise reduction to minimize any audible tape hiss, you can afford to under-record slightly; and this practice will help to ensure that you preserve all of the air, brilliance, and detail in the original sound.

You may find that, in order to achieve peak recording levels near  $0$  dB, you have to set the RECORD LEVEL control to a different position for recording FM broadcasts than when recording from phonograph records. This is normal.

**15. MIC.** The microphone socket will accept a signal from any conventional microphone whose cable terminates in a  $\frac{1}{4}$ " (6mm) phone plug. If your microphone terminates in another type of connector, plug adapters can be used to convert to the standard phone plug. Any type of microphone, with any impedance, may be used; but a low or medium impedance mike is recommended.

The microphone signal is recorded equally in both channels, as a monophonic signal in the center of the stereo stage. If you wish to make stereo recordings with two (or more) microphones, connect the mikes to a microphone preamp/mixer and then connect the output of the mixer to the LINE IN jacks.

When a microphone plug is inserted into the MIC socket, the input signal from the LINE IN jacks is automatically disconnected. (If a loud signal is present at the LINE IN jacks, a faint trace of it may still leak into the microphone input. So if you are making a critical recording with a microphone, the signal cables should be disconnected from the LINE IN jacks when the mike is used.)

In order to resume recording from a tuner or amplifier via the LINE inputs, the microphone plug must be removed from the MIC socket.

When recording a spoken voice, the most natural voice quality will usually be obtained by placing the microphone at a distance of 15 to 30 cm (6 to 12 inches) from the mouth. Holding the mike very close to the mouth, in the manner of rock singers, will produce poor sound with many microphones.

**CAUTION:** When the Model 6125 is in the RECORD mode, the signal being recorded also appears at the LINE OUT jacks and so is fed to your amplifier for monitoring. If you record with a microphone in the same room, its signal will then be amplified and reproduced by your loudspeakers. The resulting "feedback" howl could damage the speakers. To prevent this possibility, whenever you record with a microphone you should turn off your amplifier or switch it so that the tape recorder's output cannot be amplified.

## OPERATING PROCEDURES AND HINTS

### To Play Recorded Tapes

1. Before inserting a cassette, check it to be sure that the tape is straight and taut where it is exposed at the thick edge of the cassette. If necessary, insert a pencil into either tape spool and manually wind the tape until any slack is taken up.
2. Press the EJECT button to open the door. Insert the cassette with the thick edge down and with the full spool of tape at the left side. Push the door closed.
3. If the tape has been in storage for several months, it may be necessary to loosen the tape pack by fast-winding the tape. (Press FAST FORWARD to wind the tape through its entire length, then REWIND to return to the beginning.) If the tape sticks and will not fast-wind, hold the cassette in the palm of your hand and slap it face-down on a tabletop.

**CAUTION:** Strike only the flat face of the cassette against the table. If you strike the edge of the cassette against a hard surface, you could break it.

4. Set the TAPE SELECTOR to match the type of tape being played. For pre-recorded music cassettes this is usually NORMAL. In the case of chromium dioxide tapes, examine the package: if "120 microsecond" equalization is specified, use NORMAL; if not, set the switch to CrO<sub>2</sub>.

5. Set the Dolby NR switch to match the noise-reduction system that was used to record the tape. If the tape was recorded on the NAD 6125 using Dolby C (or on another tape deck equipped with Dolby C), set the Dolby NR switch to C for playback. If the tape was recorded on a machine equipped only with Dolby B, or is a commercially pre-recorded music cassette made with Dolby B encoding, set the Dolby NR switch to B.

If the tape was recorded with no noise-reduction, switch the Dolby OFF. Also, some older pre-recorded music cassettes made with Dolby B may have been so poorly processed that they sound dull with normal Dolby B playback decoding. In such cases you may obtain better sound by switching the Dolby OFF during playback and then using your amplifier's tone controls to obtain the most realistic tonal balance.

If the tape was recorded with DBX noise reduction, switch the Dolby OFF and connect the tape deck to an external DBX II noise-reduction decoder for playback.

Remember to switch the Dolby NR back to B or C when recording your own tapes.

6. Switch OFF the MPX filter (button out) to obtain the most extended high-frequency response during playback. (But remember to switch the filter back on when making recordings with Dolby B.)

7. Press PLAY.

### To Make a Recording

1. Before inserting a cassette, check it to be sure that the tape is straight and taut where it is exposed at the thick edge of the cassette. If it is not, manually wind the tape to take up the slack.

2. Press the EJECT button to open the door. Insert a blank cassette with the thick edge down and with side 1 (or A) facing you. Through the window in the cassette you should see a full spool of tape on the left side.

3. If the tape is new and has just been unwrapped for the first time, the tape pack may have developed some friction during the period of storage since it left the factory. To loosen the tape pack, press FAST FORWARD to wind the tape through its entire length, then press REWIND to return to the beginning.

4. Set the turns counter to 000. Then, as you make the recording, you can take note of the counter reading corresponding to each recorded selection.

5. Set the TAPE SELECTOR switch to match the tape that you are using.

6. Set the Dolby NR switch to C (for maximum quieting of background tape hiss), unless you are recording a tape for playback on a portable or other machine that has only Dolby B or no noise reduction at all. When recording with Dolby B, switch the MPX filter ON (button in).

7. In order to determine the optimum recording setting of the RECORD LEVEL control, it is desirable to activate the recording circuits without actually depositing a recording on the tape. To do this, press PAUSE and then REC. Observe the recording level display while setting the RECORD LEVEL control so that the highest levels in the music register are at approximately 0 dB.

When you are ready to proceed with the recording, press and release the PAUSE button to start the tape moving. (Its motion will be confirmed by the gradually changing reading of the turns counter.) Since the recording circuits have already been activated, there is no need to press REC again.

8. In most cassettes the first few inches of tape at either end is a "leader" with no magnetic coating. Remember to let the tape advance by several counts (on the turns counter) before beginning the recording.

9. To interrupt the recording at any point, press PAUSE; this will stop the tape while leaving the recording circuits and recording level display active. To resume recording, press and release PAUSE again.

10. At the end of the recording session, press STOP. If you want to continue recording on the other side of the cassette, press FAST FORWARD to advance the tape to the end of side A; remove the cassette, turn it over, and insert it with side B facing you. Press REC to resume recording.

**To Erase Tapes.** The recorder automatically erases previous recordings as a fresh recording is made. To erase an entire tape, simply turn down the RECORD LEVEL control to minimum, press REC, and record over the full length of the tape.

**Prevention of Accidental Erasure.** Every cassette is equipped with two plastic tabs in cutaway holes in the top (thin) edge of the cassette. One tab is for side A and the other for side B; when you hold the cassette so that side A faces you, its tab is on the top of the cassette near the left end.

These tabs engage a safety interlock in the recorder that permits the recording and erasing circuits to be activated. If you think that you may wish to erase and re-use a cassette in the future, do not disturb the tabs. But if you have made a valuable recording that you want to keep, you can safeguard it against any possibility of accidental over-recording and erasure by breaking off the corresponding tab. (If the valued recording occupies both sides of the cassette, break off both tabs.)

If you change your mind and decide to re-record over the tape after having removed the erasure-prevention tabs, simply cover the cutout with a piece of cellophane or other adhesive tape.

**Maintenance.** The bearings and other moving parts in this recorder are assembled with long-life lubricants and require no periodic maintenance. But in order to preserve the NAD 6125's high level of performance, all surfaces that the tape comes in contact with must be maintained free of dirt and free of magnetism.

Regular cleaning is the primary requirement. Dirt particles smaller than a two-thousandth of an inch (0.01 mm), if lodged on the polished surface of the record/play head, can cause a large falloff in high-frequency response. One easy way to clean the heads on a daily basis is to use a head-cleaning cassette (a cassette that contains a textured paper tape instead of magnetic tape). Play the cleaning cassette for several seconds before each recording or playback session, and as the cleaning tape rubs over the heads it will remove accumulated particles of dust and tape oxide.

At longer intervals—weekly or monthly depending on how heavily you use the machine—a liquid solvent or spray should be used to remove tape oxides or sticky residue deposited on the heads, capstan, and pinch roller. Tape head cleaning sprays and fluids are available from your hi-fi dealer and from other sources. We recommend a solution whose active ingredient is either alcohol (denatured or "isopropyl") or Freon (a fluorinated hydrocarbon compound); some head cleaners contain both. If you use isopropyl alcohol, check to be sure that the solution does not contain any unwanted oily substances such as Lanolin.

To clean the tape transport, remove any cassette from the machine. Use the fluid or spray to moisten a cotton swab, then use the moist swab to scrub the black erase head, the silver-colored record/play head, the steel capstan, and the black rubber pinch roller.

The door of the cassette compartment can be removed to provide easier access to the heads for cleaning and demagnetizing. The door is actually in two parts: the framework that holds the cassette, and an exterior plastic trim panel containing the NAD logo and the transparent window. Press EJECT to swing the door open; remove any cassette, and press firmly upward on the exterior surface of the door to detach it from the cassette holder. (Your NAD dealer can show you how to do this.) To re-install the door panel, align its fastening clips with the retainers on the cassette holder, and slide the panel down into place.

During months of regular use the heads and steel capstan may acquire a magnetic charge that will add hiss to all tapes played or recorded in the machine. Approximately once a year this charge should be removed by using a head de-magnetizer.

Before using the de-magnetizer, switch off the power to the recorder. Open the cassette compartment, and remove its door panel. Take away any cassettes from the vicinity. Hold the de-magnetizer away from the machine (to protect the recorder from the de-magnetizer's turn-on surge); plug in the de-magnetizer, turn it on, and then *slowly* pass its probe tip over the heads and capstan. (The probe tip may be allowed to touch the heads and capstan—but only if its metal surface is covered with a plastic sleeve or wrapped with plastic tape to prevent it from scratching the heads.) Move the probe tip *slowly* out of the cassette compartment, and move the de-magnetizer at least a meter (3 feet) away from the recorder before switching it off. If you accidentally switch off the de-magnetizer while its probe tip is within the cassette compartment, the entire de-magnetizing procedure must be repeated.

If you prefer not to do it yourself, you may have a complete annual cleaning and de-magnetizing service done for your recorder by your NAD dealer or by an independent service shop. At the same time, you may have the recorder's internal bias and Dolby circuit adjustments calibrated to match the particular brand and type of tape that you prefer to use.



**ELECTRONICS**  
LONDON/BOSTON